



Condenser

CR12– CR165



TECHNICAL MANUAL



ISO 14001
EM552085



ISO 9001
FM00542

About Airedale Products & Customer Services

WARRANTY, COMMISSIONING & MAINTENANCE

As standard, Airedale guarantees all non consumable **parts only** for a period of **18 months**, variations tailored to suit product and application are also available; please contact Airedale for full terms and details.

To further protect your investment in Airedale products, we have introduced Airedale Service, who can provide full commissioning services, comprehensive maintenance packages and service cover 24 hours a day, 365 days a year (UK mainland). For a free quotation contact our Airedale Service or your local Sales Engineer.

All Airedale products are designed in accordance with EU Directives regarding prevention of build up of water, associated with the risk of contaminants such as Legionella.

Where applicable, effective removal of condensate is achieved by gradient drainage to outlets and where used, humidification systems produce sterile, non-toxic steam during normal operation.

For effective prevention of such risk it is necessary that the equipment is maintained in accordance with Airedale recommendations.

CAUTION

Warranty cover is not a substitute for Maintenance. Warranty cover is conditional to maintenance being carried out in accordance with the recommendations provided during the warranty period. Failure to have the maintenance procedures carried out will invalidate the warranty and any liabilities by Airedale International Air Conditioning Ltd.

SPARES

A spares list for 1, 3 and 5 years will be supplied with every unit and is also available from our Spares department on request.

TRAINING

As well as our comprehensive range of products, Airedale offers a modular range of Refrigeration and Air Conditioning Training courses, for further information please contact Airedale.

CUSTOMER SERVICES

For further assistance, please e-mail: enquiries@airedale.com or telephone:

UK Sales Enquiries	+ 44 (0) 113 238 7789	enquiries@airedale.com
International Enquiries	+ 44 (0) 113 239 1000	enquiries@airedale.com
Spares Hot Line	+ 44 (0) 113 238 7878	spares@airedale.com
Airedale Service	+ 44 (0) 113 239 1000	service@airedale.com
Technical Support	+ 44 (0) 113 239 1000	tech.support@airedale.com
Training Enquiries	+ 44 (0) 113 239 1000	marketing@airedale.com

For information, visit us at our Web Site: www.airedale.com

AIAC Ltd endeavours to ensure that the information in this document is correct and fairly stated, but none of the statements are to be relied upon as a statement or representation of fact. AIAC Ltd does not accept liability for any error or omission, or for any reliance placed on the information contained in this document.

The development of Airedale products and services is continuous and the information in this document may not be up to date. It is important to check the current position with AIAC Ltd at the address stated. This document is not part of a contract or licence unless expressly agreed.

No part of this document may be reproduced or transmitted in any form or by any means, electronic or mechanical, including photocopying, recording, or information storage and retrieval systems, for any purpose other than the purchaser's personal use, without the express written permission of AIAC Ltd.

© 2014 Airedale International Air Conditioning Limited. All rights reserved. Printed in the UK.

Warranty	<p>All AIAC products or parts (non consumable) supplied for installation within the UK mainland and commissioned by an AIAC engineer, carry a full Parts & Labour warranty for a period of 12 months from the date of commissioning or 18 months from the date of despatch, whichever is the sooner.</p> <p>Parts or Equipment supplied by AIAC for installation within the UK or for Export that are properly commissioned in accordance with AIAC standards and specification, not commissioned by an AIAC engineer; carry a 12 month warranty on non consumable Parts only from the date of commissioning or 18 months from the date of despatch, whichever is the sooner.</p> <p>Parts or equipment installed or commissioned not to acceptable AIAC standards or specification invalidate all warranty.</p>
Warranty is only valid in the event that	<p>In the period between delivery and commissioning the equipment: is properly protected & serviced as per the AIAC installation & maintenance manual provided where applicable the glycol content is maintained to the correct level.</p> <p>In the event of a problem being reported and once warranty is confirmed as valid under the given installation and operating conditions, the Company will provide the appropriate warranty coverage (as detailed above) attributable to the rectification of any affected Airedale equipment supplied (excluding costs for any specialist access or lifting equipment that must be ordered by the customer).</p> <p>Any spare part supplied by Airedale under warranty shall be warranted for the unexpired period of the warranty or 3 months from delivery, whichever period is the longer.</p> <p>To be read in conjunction with the Airedale Conditions of Sale - Warranty and Warranty Procedure, available upon request.</p>
Procedure	<p>When a component part fails, a replacement part should be obtained through our Spares department. If the part is considered to be under warranty, the following details are required to process this requirement.</p> <p>Full description of part required, including Airedale's part number, if known The original equipment serial number An appropriate purchase order number</p> <p>A spares order will be raised under our warranty system and the replacement part will be despatched, usually within 24 hours should they be in stock.</p> <p>When replaced, the faulty part must be returned to Airedale with a suitably completed and securely attached "Faulty Component Return" (FCR) tag. FCR tags are available from Airedale and supplied with each Warranty order.</p> <p>On receipt of the faulty part, suitably tagged, Airedale will pass to its Warranty department, where it will be fully inspected and tested in order to identify the reason for failure, identifying at the same time whether warranty is justified or not.</p> <p>On completion of the investigation of the returned part, a full "Report on Goods Returned" will be issued. On occasion the release of this complete report may be delayed as component manufacturers become involved in the investigation.</p> <p>When warranty is allowed, a credit against the Warranty invoice will be raised. Should warranty be refused the Warranty invoice becomes payable on normal terms.</p>
Exclusions	<p>Warranty may be refused for the following reasons:</p> <ul style="list-style-type: none"> • Misapplication of product or component • Incorrect site installation • Incomplete commissioning documentation • Inadequate site installation • Inadequate site maintenance • Damage caused by mishandling • Replaced part being returned damaged without explanation • Unnecessary delays incurred in return of defective component
Returns analysis	<p>All faulty components returned under warranty are analysed on a monthly basis as a means of verifying component and product reliability as well as supplier performance. It is important that all component failures are reported correctly.</p>

Contents

General Specification	5
Unit Identification	5
Standard Features	6
Fan & Motor Assembly	7
Refrigeration	7
Electrical	7
Head Pressure Control	7
(Variable)	7
Main Electric Isolator	7
Electronically Commutated (EC) Fan Motor	8
Optional Extras – General	8
Short Case Axial Fans (SCAF)	8
Corrosion Resistant Coated Coils	8
Shut Off Valves	8
Coil Guards	8
Installation data	9
Dimensions / Weights / Positioning	9
Unit Lifting	14
General	14
Horizontal Air Discharge	14
Vertical Air Discharge	14
Performance Data – Condensers	15
Standard Condenser Fan	15
CAPACITY DATA	16
Standard Condenser Fan	16
Sound Data	17
Method of Sound Measurement	17
Semi Hemispherical	17
Sound Data - STANDARD FAN	17
Mechanical Data – Condensers	19
Electrical Data	23

General Specification

UNIT IDENTIFICATION

CR	Condenser - R410A
12 - 165	Model Size (expressed as Total Heat Rejection in kW)
H	Horizontal Air Discharge
V	Vertical Air Discharge

Introduction

This range comprises 16 Air Cooled Condenser models sizes with total heat rejection 12 - 165kW.

Custom designed for a small footprint, low sound level, slimline and aesthetically pleasing appearance.

Available in either horizontal or vertical air discharge orientation, *please specify at order.*

All units are despatched following extensive leak and pressure testing and carry a holding charge of inert gas.

The condenser range has been designed and optimised for operation with ozone benign refrigerant **R410A**.

CE Directive



Airedale certify that the equipment detailed in this manual conforms with the following EC Directives:

Electromagnetic Compatibility Directive (EMC)	2004/108/EC
Low Voltage Directive (LVD)	2006/95/EC
Machinery Directive (MD)	89/392/EEC in the version 2006/42/EC
Pressure Equipment Directive (PED)	97/23/EC

To comply with these directives appropriate national & harmonised standards have been applied. These are listed on the Declaration of Conformity, supplied with each product.

Maximum and Minimum Operation Temperature (TS) and Pressure (PS)	
Operating Temperature (TS),	TS = Min -20°C to Max 120°C *
Maximum Operating Pressure (PS)	PS = High Side 26 Barg

*Based upon the maximum machine running temperatures.

STANDARD FEATURES

Construction Unit cabinets shall be manufactured from galvanised sheet steel coated with epoxy baked powder paint to provide a durable finish.

Standard unit colour shall be Light Grey (RAL 7035).

Dual position fixing legs shall be supplied attached to the unit via captive bolts and shake proof washers.

Horizontal Air Discharge As standard, unit legs are attached and delivered in the horizontal air discharge mode as are the isolator and fan speed controller.

The legs attached to the top of the unit are for lifting and stacking and shall be removed and stored safely if not required.

IMPORTANT  **Only 2 units may be stacked together.**

Vertical Air Discharge As standard, unit legs shall be attached and delivered in the horizontal air discharge mode and shall be repositioned on site to offer vertical air discharge mode, refer to ***Dimensions / Weights / Positioning***, for details.

IMPORTANT  **To ensure the unit isolator and fan speed controller are in the correct orientation for vertical air discharge *please specify at order.***

Condenser Large surface area coil ideally positioned to optimise airflow and heat transfer, shall be manufactured from refrigeration quality copper tube with mechanically bonded aluminium fins.

The copper tube shall be internally rifled for improved heat transfer.

The factory test pressure shall not be less than 45Bar

Sweat copper pipe for brazed connection shall be provided

Standard Features**FAN & MOTOR ASSEMBLY****CR12 - CR16**

Axial flow fan assembly with low noise sickle type blades shall be supplied.

CR22 - CR165

Axial flow fan assembly with low noise sickle type blades and bellmouth.

All Models

The external rotor AC motor shall allow the use of a low power output, single phase, and speed controllable motor to power the fan.

The motor shall have inbuilt thermal overload protection and the assembly shall be supplied complete with a finger guard for protection.

Shall be available in either horizontal or vertical air discharge orientation, **please specify at order.**

Refer to *Error! Reference source not found.*, for fan options.

REFRIGERATION

Each unit shall feature as standard:
Holding Charge of inert gas.

ELECTRICAL

All electrical components shall be rated for all year round outdoor use.

All wiring shall be colour coded and numbered for identification. All units shall be wired in accordance with current local and European standards.

HEAD PRESSURE CONTROL (VARIABLE)

Variable head pressure control shall be provided by the indoor unit when standard fans or optional EC fans are selected.

For optional short case axial fan selection, the head pressure control shall be provided by the outdoor unit; refer to **Short Case Axial Fans.**

MAIN ELECTRIC ISOLATOR

A weatherproof mains isolator shall be fitted to ensure complete unit isolation of the electrical panel during adjustment and maintenance.

Optional Extras - Energy Saving

ELECTRONICALLY COMMUTATED (EC) FAN MOTOR

Shall incorporate external EC rotor motor technology to provide highly accurate discreet speed control. The fans offer maximum air flow performance while keeping sound levels to a minimum.

Each fan shall incorporate electronically commutated DC motor control using semiconductor modules responding to a signal from the Airedale indoor unit.

EC motors are DC motors with integrated AC to DC conversion; this gives the flexibility of connecting to AC mains with the efficiency and simple speed control of a DC motor. The EC fan shall offer significant power reduction in comparison with equivalent AC fan at both full and modulated fan speeds. The inbuilt EC fan control module shall allow for fan speed modulation from 0-100%, the modulating range of a standard AC fan is typically 40-100% of full fan speed.

Optional Extras – General

SHORT CASE AXIAL FANS (SCAF)

Short case axial fans shall be supplied for indoor installations where discharge air requires to be ducted to an outdoor location. The fans shall meet duty plus nominal 75Pa of external static pressure.

Head pressure control shall be maintained by a modulating fan speed controller fitted to the outdoor unit. The controller shall be rated to IP54 for outdoor use and operate accurately in ambient temperatures down to a minimum of -20°C.

CORROSION RESISTANT COATED COILS

For aggressive atmospheres a corrosion resistant coating shall be applied to the aluminium fins.

SHUT OFF VALVES

Where unit isolation for easier maintenance is required, shut off valves shall be supplied loose for on site fitment.

COIL GUARDS

Protective mesh guards can be fitted to each of the outer coils to protect against damage.

Installation data

The range of condensers and dry coolers are grouped together for easier identification.
Case sizes 1-5 (16 Condensers, 14 Dry coolers)

Outdoor Unit			
CR12H-0		DR10H-0	
CR16H-0	A	DR12H-0	
CR22H-0		DR15H-0	B
CR30H-0	B	DR20H-0	
CR36H-0		DR25H-0	
CR35H-0		DR30H-0	C
CR50H-0		DR35H-0	
CR60H-0	C	DR40H-0	
CR65H-0		DR45H-0	
CR75H-0		DR50H-0	D
CR80H-0		DR55H-0	
CR95H-0	D	DR70H-0	
CR105H-0		DR75H-0	
CR130H-0		DR95H-0	E
CR140H-0			
CR165H-0	E		

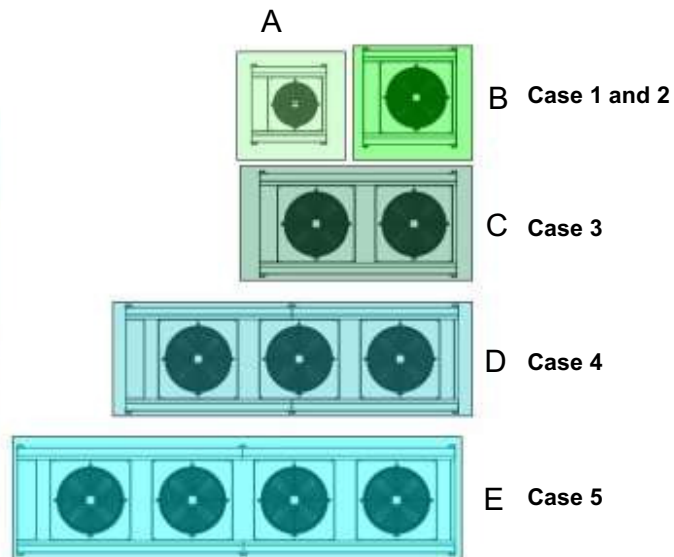

Dimensions / Weights / Positioning

IMPORTANT  Unit diagrams can be supplied on request.

The following illustrations show the unit following fixing leg re-orientation, instructions are provided for this at delivery.

IMPORTANT 

The legs attached to the top of the unit are for lifting and stacking and may be removed and stored safely if not required.

Stacking units

Only 2 units may be stacked together. In addition to the standard minimum clearances around the unit further space is required.

Positioning condensers on top of each other can cause the bottom unit to be starved of air.

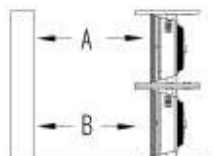

A= 1.5m (Two stacked units)
B= 0.5m (For single unit)

Horizontal case size 1 and 2 (1 fan)

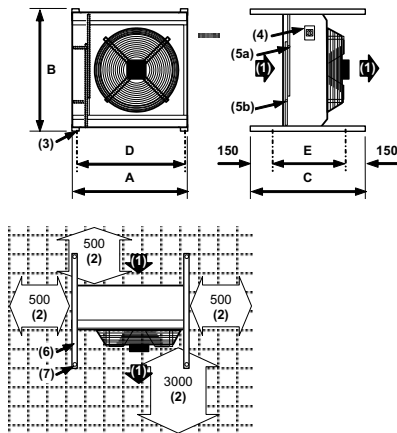

Diagram illustrated in mm

- (1) Airflow
- (2) Minimum clearances
- (3) 12.7mm fixing hole
- (4) Mains electric isolator
- (5) **Service connections to left hand side of the unit:**
 a = Discharge gas inlet (ALWAYS above (b))
 b = Liquid outlet
- (6) Top brackets may be used to secure unit of similar size on top, using, 2 x 12.7mm fixing holes
- (7) 40mm lifting holes

Horizontal case size1 (1 fan)

	DIMENSIONS (mm)					WEIGHTS (kg)		
	Standard Fan					Standard AC Fan	Optional EC Fan	Optional SCAF
	A	B	C	D	E			
CR12	907	972	1000	845	700	62	67	67
CR16	907	972	1000	845	700	70	76	75
CR22	1102	1167	1000	1040	700	77	83	88
CR26	1102	1167	1000	1040	700	93	105	90
CR30	1102	1167	1000	1040	700	90	96	101
CR35	1102	1167	1000	1040	700	106	118	103

Vertical case size 1 and 2 (1 Fan)

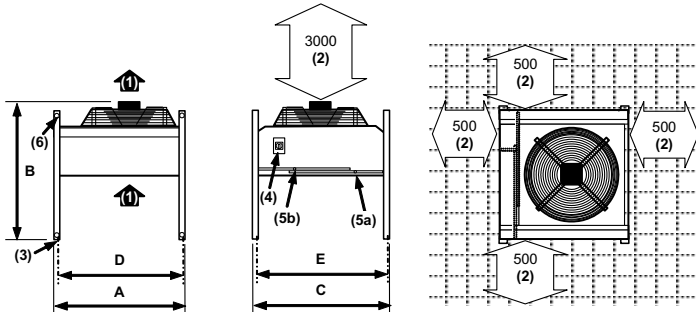

Diagram illustrated in mm

- (1) Airflow
- (2) Minimum clearances
- (3) 12.7mm fixing hole
- (4) Mains electric isolator
- (5) **Service connections to left hand side of the unit:**
 a = Liquid outlet
 b = Discharge gas inlet
- (6) 40mm lifting holes

Vertical case size1 (1 fan)

	DIMENSIONS (mm)					WEIGHTS (kg)				
	Standard Fan					Fan Options		Standard AC Fan	Optional EC Fan	Optional SCAF
	A	B	C	D	E	SCAF B	EC B			
CR12	907	1076	972	847	912	1080	1065	62	67	67
CR16	907	1076	972	847	912	1080	1065	70	76	75
CR22	1102	1090	1167	1042	1107	1130	1127	77	83	88
CR26	1102	1155	1167	1042	1107	1140	1170	93	105	90
CR30	1102	1090	1167	1042	1107	1130	1127	90	96	101
CR35	1102	1155	1167	1042	1107	1140	1170	106	118	103

Horizontal case size 3 (2 Fans)

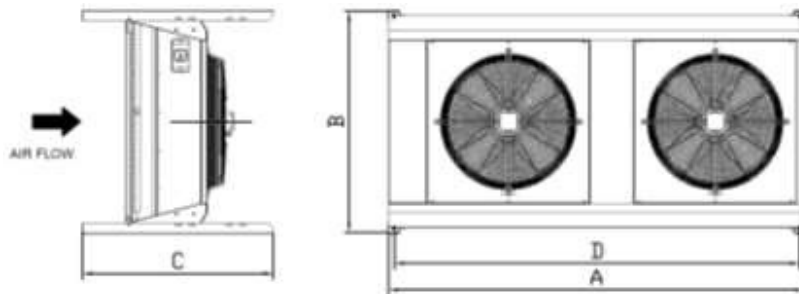

	DIMENSIONS (mm)					WEIGHTS (kg)		
	Standard Fan					Standard AC Fan	Optional EC Fan	Optional SCAF
	A	B	C	D	E			
CR50	2184	1167	1000	2121	700	132	145	154
CR60	2184	1167	1000	2121	700	165	188	159
CR65	2184	1167	1000	2121	700	162	175	184
CR75	2184	1167	1000	2121	700	195	218	189

Vertical case size 3 (2 Fans)

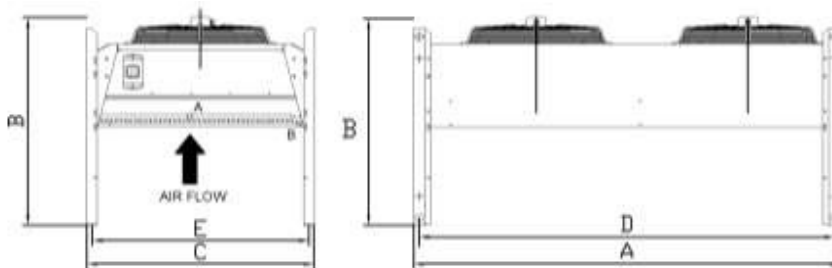

	DIMENSIONS (mm)							WEIGHTS (kg)		
	Standard Fan					Fan Options		Standard AC Fan	Optional EC Fan	Optional SCAF
	A	B	C	D	E	SCAF	EC			
CR50	2184	1090	1167	2124	1107	1130	1127	132	145	154
CR60	2184	1155	1167	2124	1107	1140	1170	165	188	159
CR65	2184	1090	1167	2124	1107	1130	1127	162	175	184
CR75	2184	1155	1167	2124	1107	1140	1170	195	218	189

Horizontal case size 4 (3 Fans)

Optional Short Case Axial Fan (SCAF)

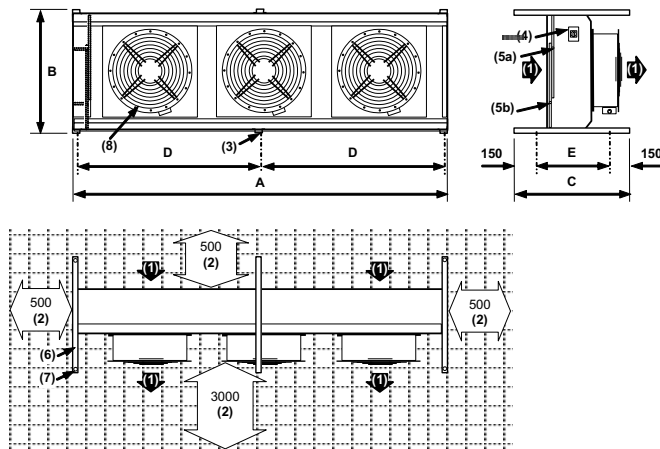

Diagram illustrated in mm

- (1) Airflow
- (2) Minimum clearances
- (3) 12.7mm fixing hole
- (4) Mains electric isolator
- (5) **Service connections to left hand side of the unit:**
a = Discharge gas inlet (ALWAYS above (b))
b = Liquid outlet
- (6) Top brackets may be used to secure unit of similar size on top, using, 2 x 12.7mm fixing holes
- (7) 40mm lifting holes
- (8) Optional Short Case Axial Fan with integral duct fixing holes

	DIMENSIONS (mm)					WEIGHTS (kg)		
	Standard Fan					Standard AC Fan	Optional EC Fan	Optional SCAF
	A	B	C	D	E			
CR80	3565	1167	1000	1752	700	208	228	242
CR95	3565	1167	1000	1752	700	258	293	249
CR105	3565	1167	1000	1752	700	260	280	294
CR130	3565	1140	1167	1752	1107	310	345	301

The SCAF fans in the horizontal mode do not obstruct past the mounting feet.

Vertical case size 4 (3 fans)

Optional Short Case Axial Fan (SCAF)

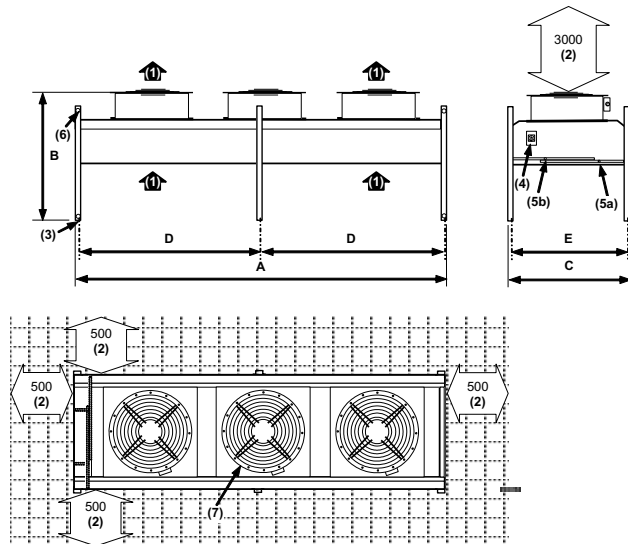

Diagram illustrated in mm

- (1) Airflow
- (2) Minimum clearances
- (3) 12.7mm fixing hole
- (4) Mains electric isolator
- (5) **Service connections to left hand side of the unit:**
a = Liquid outlet
b = Discharge gas inlet
- (6) 40mm lifting holes
- (7) Optional short case axial fan with integral duct fixing holes

Vertical case size 3 (3 fans)

	DIMENSIONS (mm)						WEIGHTS (kg)			
	Standard Fan					Fan Options		Standard AC Fan	Optional EC Fan	Optional SCAF
	A	B	C	D	E	SCAF B	EC B			
CR80	3565	1090	1167	1753	1107	1130	1127	208	228	242
CR95	3565	1155	1167	1753	1107	1140	1170	258	293	249
CR105	3565	1090	1167	1753	1107	1130	1127	260	280	294
CR130	3565	1155	1167	1753	1107	1140	1170	310	345	301

Horizontal case size 5 (4 fans)

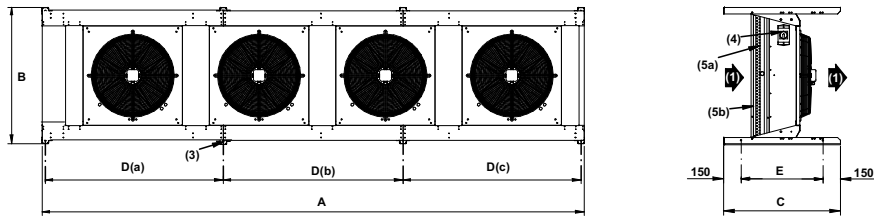

For Minimum Clearances (2) see previous outdoor units in horizontal configuration

Diagram illustrated in mm

- (1) Airflow
- (2) Minimum clearances
- (3) 12.7mm fixing hole
- (4) Mains electric isolator
- (5) **Service connections to left hand side of the unit:**
a = Discharge gas inlet (ALWAYS above (b))
b = Liquid outlet
- (6) Top brackets may be used to secure unit of similar size on top, using, 2 x 12.7mm fixing holes
- (7) 40mm lifting holes

	DIMENSIONS (mm)							WEIGHTS (kg)		
	Standard Fan							Standard AC Fan	Optional EC Fan	Optional SCAF
	A	B	C	D(a)	D(b)	D(c)	E			
CR140	4641	1167	1000	1524	1539	1524	700	349	375	394
CR165	4641	1167	1000	1524	1539	1524	700	415	462	404

CAUTION A vertical air discharge unit is recommended for installation in windy locations or wherever a horizontal airflow would be obstructed.

Vertical case size 5 (4 fans)

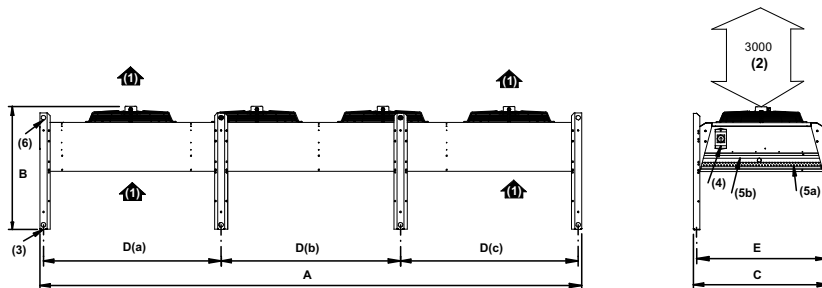

For minimum clearances (2) see previous outdoor units in vertical configuration

Diagram illustrated in mm

- (1) Air flow
- (2) Minimum clearances
- (3) 12.7mm fixing hole
- (4) Mains electric isolator
- (5) **Service connections to left hand side of the unit:**
a = Liquid outlet
b = Discharge gas inlet
- (6) 40mm lifting holes
- (7) Optional short case axial fan with integral duct fixing holes

	DIMENSIONS (mm)							WEIGHTS (kg)				
	Standard Fan							Fan Options		Standard AC Fan	Optional EC Fan	Optional SCAF
	A	B	C	D(a)	D(b)	D(c)	E	SCAF	EC			
								B	B			
CR140	4641	1090	1167	1524	1539	1524	1107	1130	1127	349	375	394
CR165	4641	1155	1167	1524	1539	1524	1107	1140	1170	415	462	404

Unit Lifting

GENERAL

Employ lifting specialists
Local codes and regulations relating to the lifting of this type of equipment should be observed
Each chain/sling must be capable of lifting the whole unit
Lift the unit slowly and evenly

IMPORTANT ▼ Only use lifting points provided.

Do not use 1 chain between 2 lifting points to avoid load shift.

Ensure that chains/slings DO NOT crush the casework, coil or fan assemblies.

If the unit is dropped it should immediately be checked for damage and reported to Airedale.

Airedale will accept no responsibility for mishandling during the positioning of the equipment.

CAUTION ▼ Check the unit is as ordered, discrepancies or transit damage should be reported to Airedale immediately.

HORIZONTAL AIR DISCHARGE

The unit is delivered in horizontal air discharge configuration secured to a pallet. Where possible the unit should be moved with the pallet in place.

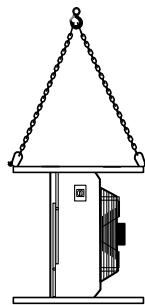

Use 4 lifting eyes attached to 4 individual slings/chains (supplied by others) and attach 2 to each top leg using the holes provided as illustrated.

VERTICAL AIR DISCHARGE

The unit is delivered in horizontal air discharge configuration (with the mains isolator and fan speed controller already configured for vertical air discharge) secured to a pallet. Where possible the unit should be moved with the pallet in place.

Before lifting into final position, the unit legs should be re-orientated, refer to instructions provided at delivery.

CAUTION ▼ Care should be taken to ensure the unit does not sustain damage before it is lifted into final position.

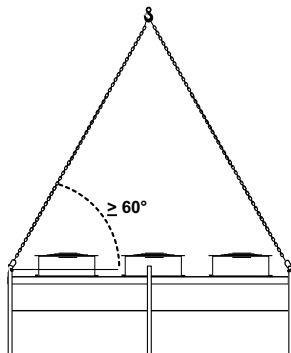

Use 4 lifting eyes attached to 4 individual slings/chains (supplied by others) and attach 1 to the top of each of the 4 corner legs using the holes provided as illustrated.

Performance Data – Condensers

STANDARD CONDENSER FAN

Mean Condensing Temperature °C	Ambient						
	25°C	30°C	35°C	40°C	45°C	48°C	
	Output (kW)	Output (kW)	Output (kW)	Output (kW)	Output (kW)	Output (kW)	
CR12	35	8.8	3.3	-	-	-	-
	40	13.8	8.8	3.4	-	-	-
	45	19.0	14.0	8.9	3.6	-	-
	50	24.4	19.2	14.1	9.1	3.8	-
	55	29.8	24.7	19.5	14.4	9.3	4.1
CR16	35	11.9	5.0	-	-	-	-
	40	18.2	12.0	5.2	-	-	-
	45	24.7	18.4	12.1	5.4	-	-
	50	31.3	25.0	18.6	12.3	5.6	-
	55	38.2	31.8	25.4	19.0	12.6	6.5
CR22	35	15.4	6.2	-	-	-	-
	40	24	15.5	6.4	-	-	-
	45	32.8	24.2	15.7	6.7	-	-
	50	41.7	33.1	24.6	16.0	7.0	-
	55	51.0	42.3	33.7	25.1	16.4	7.7
CR26	35	19.2	7.8	-	-	-	-
	40	29.9	19.4	8.0	-	-	-
	45	40.9	30.3	19.6	8.4	-	-
	50	52.1	41.4	30.7	20.0	8.8	-
	55	63.5	52.9	42.1	31.4	20.5	9.9
CR30	35	19.8	8.1	-	-	-	-
	40	30.6	20.0	8.4	-	-	-
	45	41.7	30.9	20.2	8.7	-	-
	50	53.1	42.1	31.3	20.5	9.2	-
	55	64.8	53.8	42.8	31.9	21.0	9.8
CR35	35	25.4	10.5	-	-	-	-
	40	39.4	25.7	10.9	-	-	-
	45	53.6	39.7	26.0	11.3	-	-
	50	68.1	54.2	40.3	26.4	11.8	-
	55	83.1	69.0	55.0	41.1	27	12.9
R50	35	33.7	13.7	-	-	-	-
	40	52.6	34.0	14.2	-	-	-
	45	71.7	53.1	34.4	14.8	-	-
	50	91.3	72.5	53.8	35.1	15.5	-
	55	111.5	92.6	73.7	54.8	35.9	16.9
CR60	35	42.3	65.9	-	-	-	-
	40	65.9	42.7	17.9	-	-	-
	45	89.8	66.6	43.2	18.6	-	-
	50	114.3	91.0	67.6	44.0	19.5	-
	55	139.5	116.0	92.5	68.9	45.1	20.3

(1) Output kW refers to the condenser heat rejection.

CAPACITY DATA

STANDARD CONDENSER FAN

Mean Condensing Temperature °C	Ambient						
	25°C	30°C	35°C	40°C	45°C	48°C	
	Output (kW)	Output (kW)	Output (kW)	Output (kW)	Output (kW)	Output (kW)	
CR65	35	44.9	18.6	-	-	-	-
	40	69.1	45.2	19.3	-	-	-
	45	93.8	69.7	45.6	20	-	-
	50	119.2	94.8	70.6	46.4	21	-
	55	145.5	120.9	96.4	72	47.5	22.6
CR75	35	58.2	24.6	-	-	-	-
	40	89.5	58.6	25.4	-	-	-
	45	121.4	90.3	59.3	26.3	-	-
	50	154.1	122.8	91.6	60.3	27.5	-
	55	187.8	156.3	124.8	93.4	61.7	30.1
CR80	35	55.3	23	-	-	-	-
	40	85.8	55.8	23.8	-	-	-
	45	116.7	86.6	56.5	24.7	-	-
	50	148.4	118.1	87.8	57.5	25.8	-
	55	180.9	150.4	120	89.5	58.9	28.3
CR95	35	69.7	29.2	-	-	-	-
	40	108	70.4	30.2	-	-	-
	45	147	109.3	71.3	31.4	-	-
	50	186.7	148.9	110.9	72.6	32.8	-
	55	227.6	189.5	151.4	113.1	74.5	37
CR105	35	72.1	30	-	-	-	-
	40	110.8	72.6	31	-	-	-
	45	150.4	111.7	73.3	32.2	-	-
	50	191.1	152.1	113.2	74.5	33.8	-
	55	233.3	193.8	154.6	115.5	76.3	36.4
CR130	35	95.3	40.5	-	-	-	-
	40	146.3	95.9	41.7	-	-	-
	45	198.3	147.6	97	43.2	-	-
	50	251.6	200.6	149.7	98.6	45.1	-
	55	306.6	255.2	203.9	152.6	101	50.6
CR140	35	95.8	40.2	-	-	-	-
	40	147.2	96.3	41.5	-	-	-
	45	199.6	148.3	97.2	43	-	-
	50	253.5	201.6	150.1	98.7	44.9	-
	55	309	256.8	204.8	152.9	101	48.3
CR165	35	124.8	53.5	-	-	-	-
	40	191.6	125.6	55	-	-	-
	45	259.6	193.2	126.9	56.9	-	-
	50	329	262.3	195.7	128.9	59.2	-
	55	400.6	333.4	266.4	199.3	131.8	66.6

(1) Output kW refers to the total heat rejection

Sound Data

METHOD OF SOUND MEASUREMENT

All sound data quoted has been measured in the third-octave band limited values, using a Real Time Analyser calibrated sound intensity meter in accordance with BS EN ISO9614 Part 1: 1995.

All Sound Power Levels quoted are calculated from measured sound intensity according BS EN ISO9614 Part 1: 1995.

SEMI HEMISPHERICAL

Sound Pressure Levels are calculated from sound power using the semi-hemispherical method where the noise source is in junction with 2 boundaries i.e. the floor and 1 wall.

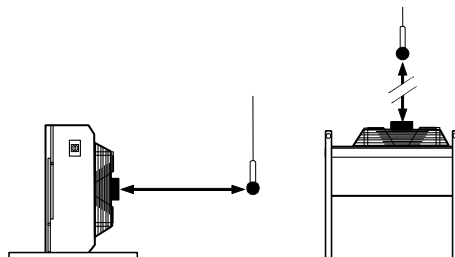

SOUND DATA - STANDARD FAN

IMPORTANT  The sound data quoted is based on the unit having the STANDARD FAN running at FULL SPEED under normal operating conditions.

For sound data of optional fan selections, please contact Airedale.

Horizontal

	Sound Measurement	Overall dB(A)	Frequency (Hz) dB							
			63	125	250	500	1000	2000	4000	8000
CR12	Power	74	72	83	76	68	68	65	60	50
	Pressure @10m	46	44	55	48	40	40	37	32	22
CR16	Power	74	72	83	76	68	68	65	60	50
	Pressure @10m	46	44	55	48	40	40	37	32	22
CR22	Power	78	82	87	74	74	73	70	63	62
	Pressure @10m	50	54	59	46	46	45	42	35	34
CR26	Power	82	83	80	82	79	78	74	67	59
	Pressure @10m	54	55	52	54	51	50	46	39	31
CR30	Power	78	82	87	74	74	73	70	63	62
	Pressure @10m	50	54	59	46	46	45	42	35	34
CR35	Power	82	83	80	82	79	78	74	67	59
	Pressure @10m	54	55	52	54	51	50	46	39	31
CR50	Power	81	85	90	77	77	76	73	66	65
	Pressure @10m	53	57	62	49	49	48	45	38	37
CR60	Power	85	86	83	85	82	81	77	70	62
	Pressure @10m	57	58	55	57	54	53	49	42	34
CR65	Power	81	85	90	77	77	76	73	66	65
	Pressure @10m	53	57	62	49	49	48	45	38	37
CR75	Power	85	86	83	85	82	81	77	70	62
	Pressure @10m	57	58	55	57	54	53	49	42	34
CR80	Power	83	80	90	80	77	79	75	68	67
	Pressure @10m	55	52	62	52	49	51	47	40	39
CR95	Power	87	88	85	87	84	83	79	72	64
	Pressure @10m	59	60	57	59	56	55	51	44	36
CR105	Power	82	80	90	80	77	79	75	68	67
	Pressure @10m	55	52	62	52	49	51	47	40	39
CR130	Power	87	88	85	87	84	83	79	72	64
	Pressure @10m	59	60	57	59	56	55	51	44	36
CR140	Power	84	81	90	81	78	81	77	70	69
	Pressure @10m	56	53	62	53	50	53	49	42	41
CR165	Power	88	89	86	88	85	84	80	73	65
	Pressure @10m	60	61	58	60	57	56	52	45	37

Vertical

	Sound Measurement	Overall dB(A)	Frequency (Hz) dB							
			63	125	250	500	1000	2000	4000	8000
CR12	Power	75	69	86	75	68	69	65	61	51
	Pressure @ 10m	47	41	58	47	40	41	37	33	23
CR16	Power	75	69	86	75	68	69	65	61	51
	Pressure @ 10m	47	41	58	47	40	41	37	33	23
CR22	Power	79	80	90	73	74	74	70	64	63
	Pressure @ 10m	51	52	62	45	46	46	42	36	35
CR26	Power	83	80	83	82	79	79	73	68	60
	Pressure @ 10m	55	52	55	54	51	51	45	40	32
CR30	Power	79	80	90	73	74	74	70	64	63
	Pressure @ 10m	51	52	62	45	46	46	42	36	35
CR35	Power	83	80	83	82	79	79	73	68	60
	Pressure @ 10m	55	52	55	54	51	51	45	40	32
CR50	Power	82	83	93	76	77	77	73	67	66
	Pressure @ 10m	54	55	65	48	49	49	45	39	38
CR60	Power	86	83	86	85	82	82	76	71	63
	Pressure @ 10m	58	55	58	57	54	54	48	43	35
CR65	Power	82	83	93	76	77	77	73	67	66
	Pressure @ 10m	54	55	65	48	49	49	45	39	38
CR75	Power	86	83	86	85	82	82	76	71	63
	Pressure @ 10m	58	55	58	57	54	54	48	43	35
CR80	Power	84	78	93	79	78	80	75	69	68
	Pressure @ 10m	56	50	65	51	50	52	47	41	40
CR95	Power	88	85	88	87	84	84	78	73	65
	Pressure @ 10m	60	57	60	59	56	56	50	45	37
CR105	Power	84	78	93	79	78	80	75	69	68
	Pressure @ 10m	56	50	65	51	50	52	47	41	40
CR130	Power	88	85	88	87	84	84	78	73	65
	Pressure @ 10m	60	57	60	59	56	56	50	45	37
CR140	Power	85	78	94	81	78	81	77	71	70
	Pressure @ 10m	57	50	66	53	50	53	49	43	42
CR165	Power	89	86	89	88	85	85	79	74	66
	Pressure @ 10m	61	58	61	60	57	57	51	46	38

Mechanical Data – Condensers

	CR12	CR16	CR22	CR26	CR30
Total Heat of Rejection CR (1) kW	14.1	18.6	24.6	30.7	31.3
Dimensions - Horizontal (2)					
H x W x L mm	972 x 1000 x 907	972 x 1000 x 907	1167 x 1000 x 1102	1167 x 1000 x 1102	1167 x 1000 x 1102
Dimensions - Vertical (2)					
H x W x L mm	1076 x 972 x 907	1076 x 972 x 907	1090 x 1167 x 1102	1155 x 1000 x 1102	1090 x 1167 x 1102
Weight Machine kg	62	70	77	93	90
Construction Material/Colour	Galvanised Sheet Steel, Epoxy Baked Powder Paint - Light Grey (RAL 7035)				
Condenser Dry Cooler	Air Cooled - Rifled Copper Tube/Turbulated Aluminium Fins Air Cooled - Copper Tube/Turbulated Aluminium Fins				
Total Face Area m ²	0.58	0.58	0.91	0.91	0.91
Nominal Airflow Discharge m ³ /s	1.3	1.1	2.3	3.3	1.9
	-H Horizontal or -V Vertical (Please Specify at Order)				
Fan & Motor	Axial				
Quantity	1	1	1	1	1
Diameter mm	500	500	630	710	630
Maximum Speed rpm	910	910	895	930	895
Refrigeration - CR	Single Circuit				
Refrigerant Type	R410A				
Holding Charge	Inert Gas				
Coil Volume l	3.0	6.0	4.7	4.7	9.3
Refrigerant Charge (3) kg	1.4	2.7	2.2	2.2	4.3
Dry Cooler					
Internal Water Volume L	6.6				
Nominal Flowrate l/s	0.53				
Pressure Drop kPa	11.9				
Connections					
Liquid Line – Sweat in	5/8	5/8	5/8	5/8	3/4
Discharge Line – Sweat in	5/8	5/8	5/8	5/8	3/4
OPTIONAL EXTRAS					
Short Case Axial Fan	Designed to 75 Pa ESP				
Dimensions - Horizontal					
H x W x L mm	972 x 1000 x 907	972 x 1000 x 907	1167 x 1000 x 1102	1167 x 1000 x 1102	1167 x 1000 x 1102
Dimensions - Vertical					
H x W x L mm	1080 x 972 x 907	1080 x 972 x 907	1130 x 1167 x 1102	1140 x 1167 x 1102	1130 x 1167 x 1102
Weight Machine kg	67	75	88	105	101
EC Fan					
Dimensions - Horizontal					
H x W x L mm	972 x 1000 x 907	972 x 1000 x 907	1167 x 1000 x 1102	1167 x 1000 x 1102	1167 x 1000 x 1102
Dimensions - Vertical					
H x W x L mm	1065 x 972 x 907	1065 x 972 x 907	1127 x 1167 x 1102	1170 x 1167 x 1102	1127 x 1167 x 1102
Weight Machine kg	67	76	83	90	96

(1) Nominal data based on 35°C ambient and a 50°C mean condensing temperature and using standard fan.
All performance data is supplied in accordance with BS EN 14511-1:2013

(2) Overall dimensions for clearance,.

(3) For guidance only.

Mechanical Data- Condensers

		CR35	CR50	CR60	CR65	CR75
Total Heat of Rejection CR	(1) kW	40.3	53.8	67.6	70.6	91.6
Dimensions - Horizontal	(2) mm	1167 x 1000 x 1102	1167 x 1000 x 2184	1167 x 1000 x 2184	1167 x 1000 x 2184	1167 x 1000 x 2184
Dimensions - Vertical	(2) mm	1155 x 1167 x 1102	1090 x 1167 x 2184	1155 x 1167 x 2184	1090 x 1167 x 2184	1155 x 1167 x 2184
Weight Machine	kg	106	132	165	162	195
Construction Material/Colour		Galvanised Sheet Steel, Epoxy Baked Powder Paint - Light Grey (RAL 7035)				
Condenser Dry Cooler		Air Cooled - Rifled Copper Tube/Turbulated Aluminium Fins				
Total Face Area	m ²	0.91	2.11	2.11	2.11	2.11
Nominal Airflow	m ³ /s	2.6	4.8	7	4.2	5.7
Discharge		-H Horizontal or -V Vertical (Please Specify at Order)				
Fan & Motor		Axial				
Quantity		1	2	2	2	2
Diameter	mm	710	630	710	630	710
Maximum Speed	rpm	930	895	930	895	930
Refrigeration-CR		Single Circuit				
Refrigerant Type		R410A				
Holding Charge		Inert Gas				
Coil Volume	l	9.3	10.7	10.7	21.4	21.4
Refrigerant Charge	(3) kg	4.3	4.9	4.9	9.8	9.8
Dry Cooler						
Internal Water Volume	L	11.9	14.8	14.8	26.7	26.7
Nominal Flowrate	l/s	0.9	1.2	1.47	1.64	2.1
Pressure Drop	kPa	46.4	15.3	20.5	38.5	60.4
Connections						
Liquid Line - Sweat	in	3/4	3/4	3/4	3/4	3/4
Discharge Line - Sweat	in	3/4	1 1/8	1 1/8	1 1/8	1 1/8
OPTIONAL EXTRAS						
Short Case Axial Fan		Designed to 75 Pa ESP				
Dimensions - Horizontal						
H x W x L	mm	1167 x 1000 x 1102	1167 x 1000 x 2184	1167 x 1000 x 2184	1167 x 1000 x 2184	1167 x 1000 x 2184
Dimensions - Vertical						
H x W x L	mm	1140 x 1167 x 1102	1130 x 1167 x 2184	1140 x 1167 x 2184	1130 x 1167 x 2184	1140 x 1167 x 2184
Weight Machine	kg	118	154	188	184	218
EC Fan						
Dimensions - Horizontal						
H x W x L	mm	1167 x 1000 x 1102	1167 x 1000 x 2184	1167 x 1000 x 2184	1167 x 1000 x 2184	1167 x 1000 x 2184
Dimensions - Vertical						
H x W x L	mm	1170 x 1167 x 1102	1127 x 1167 x 2184	1170 x 1167 x 2184	1127 x 1167 x 2184	1170 x 1167 x 2184
Weight Machine	kg	103	145	159	175	189

- (1) Nominal data based on 35°C ambient and a 50°C mean condensing temperature and using standard fan.
All performance data is supplied in accordance with BS EN 14511-1:2013
- (2) Overall dimensions for clearance.
- (3) For guidance only.

Mechanical Data- Condensers

		CR80	CR95	CR105
Total Heat of Rejection CR	(1) kW	87.8	110.9	113.2
Dimensions - Horizontal	(2)			
H x W x L	mm	1167 x 1000 x 3565	1167 x 1000 x 3565	1167 x 1000 x 3565
Dimensions - Vertical	(2)			
H x W x L	mm	1090 x 1167 x 3565	1155 x 1167 x 3565	1090 x 1167 x 3565
Weight				
Machine	kg	208	258	260
Construction		Galvanised Sheet Steel, Epoxy Baked Powder Paint - Light Grey (RAL 7035)		
Condenser		Air Cooled - Rifled Copper Tube/Turbulated Aluminium Fins		
Dry Cooler		Air Cooled - Copper Tube/Turbulated Aluminium Fins		
Total Face Area	m ²	3.63	3.63	3.63
Nominal Airflow	m ³ /s	7.5	10.8	6.6
Discharge		-H Horizontal or -V Vertical (Please Specify at Order)		
Fan & Motor			Axial	
Quantity		3	3	3
Diameter	mm	630	710	630
Maximum Speed	rpm	895	930	895
Refrigeration - CR			Single Circuit	
Refrigerant Type			R410A	
Holding Charge			Inert Gas	
Coil Volume	l	18.3	18.3	36.6
Refrigerant Charge	(3) kg	8.4	8.4	16.7
Dry Cooler				
Internal Water Volume	L	23.1	23.1	43.2
Water flowrate	l/s	2.0	2.5	2.6
Pressure Drop	kPa	48.5	70	32
Connections				
Liquid Line - Sweat	in	7/8	7/8	7/8
Discharge Line - Sweat	in	1 3/8	1 3/8	1 3/8
OPTIONAL EXTRAS				
Short Case Axial Fan		Designed to 75 Pa ESP		
Dimensions - Horizontal				
H x W x L	mm	1167 x 1000 x 3565	1167 x 1000 x 3565	1167 x 1000 x 3565
Dimensions - Vertical				
H x W x L	mm	1130 x 1167 x 3565	1140 x 1167 x 3565	1130 x 1167 x 3565
Weight				
Machine	kg	242	249	294
EC Fan				
Dimensions - Horizontal				
H x W x L	mm	1167 x 1000 x 3565	1167 x 1000 x 3565	1167 x 1000 x 3565
Dimensions - Vertical				
H x W x L	mm	1127 x 1167 x 3565	1170 x 1167 x 3565	1127 x 1167 x 3565
Weight				
Machine	kg	228	293	280

(1) Nominal data based on 35°C ambient and a 50°C mean condensing temperature and using standard fan.
All performance data is supplied in accordance with BS EN 14511-1:2013

(2) Overall dimensions for clearance; refer to **Dimensional & Installation Data**, for detail.

(3) For guidance only.

Mechanical Data- Condensers

		CR130	CR140	CR165
Total Heat of Rejection CR	(1) kW	149.7	150.1	195.7
Dimensions - Horizontal	(2) mm	1167 x 1000 x 3565	1167 x 1000 x 4641	1167 x 1000 x 4641
Dimensions - Vertical	(2) mm	1155 x 1167 x 3565	1090 x 1167 x 4641	1155 x 1167 x 4641
Weight Machine	kg	310	349	415
Construction Material/Colour		Galvanised Sheet Steel, Epoxy Baked Powder Paint - Light Grey (RAL 7035)		
Condenser Dry Cooler		Air Cooled - Rifled Copper Tube/Turbulated Aluminium Fins Air Cooled - Copper Tube/Turbulated Aluminium Fins		
Total Face Area	m ²	3.63	4.8	4.8
Nominal Airflow Discharge	m ³ /s	9.3	8.7	12.4
		-H Horizontal or -V Vertical (Please Specify at Order)		
Fan & Motor			Axial	
Quantity		3	4	4
Diameter	mm	710	630	710
Maximum Speed	rpm	930	895	930
Refrigeration - CR			Single Circuit	
Refrigerant Type			R410A	
Holding Charge			Inert Gas	
Coil Volume	l	36.6	TBC	TBC
Refrigerant Charge	(3) kg	16.7	TBC	TBC
Dry Cooler				
Internal Water Volume	L	43.2	55.9	55.9
Water flowrate	l/s	3.4	3.5	4.6
Pressure Drop	kPa	53	62	94
Connections				
Liquid Line - Sweat	in	7/8	7/8	7/8
Discharge Line - Sweat	in	1 3/8	1 3/8	1 3/8
OPTIONAL EXTRAS				
Short Case Axial Fan		Designed to 75 Pa ESP		
Dimensions - Horizontal				
H x W x L	mm	1140 x 1000 x 3565	1167 x 1000 x 4641	1167 x 1000 x 4641
Dimensions - Vertical				
H x W x L	mm	1140 x 1167 x 3565	1130 x 1167 x 4641	1140 x 1167 x 4641
Weight Machine	kg	345	394	404
EC Fan				
Dimensions - Horizontal				
H x W x L	mm	1167 x 1000 x 3565	1167 x 1000 x 4641	1167 x 1000 x 4641
Dimensions - Vertical				
H x W x L	mm	1170 x 1167 x 3565	1127 x 1167 x 4641	1170 x 1167 x 4641
Weight Machine	kg	301	375	462

(1) Nominal data based on 35°C ambient and a 50°C mean condensing temperature and using standard fan.
All performance data is supplied in accordance with BS EN 14511-1:2013

(2) Overall dimensions for clearance; refer to **Dimensional & Installation Data**, for detail.

(3) For guidance only.

Electrical Data

Condenser		CR12	CR16	CR22	CR26	CR30	CR35	CR50	CR60	CR65
Unit Data (1)										
Nominal Run Amps	A	1.2	1.2	2.6	1.7	2.6	1.7	5.2	3.3	5.2
Maximum Start Amps	A	4.1	4.1	9.2	6.1	9.2	6.1	18.3	12.2	18.3
Recommended Mains Fuse	A	6	6	6	6	6	6	10	6	10
Max Mains Cable Incoming	mm ²	6	6	6	6	6	6	6	6	6
Mains Supply 50Hz		230V/1Ph		400V/3Ph		230V/1Ph	400V/3Ph	230V/1Ph	400V/3Ph	230V/1Ph
Fan - Per Fan										
Quantity		1	1	1	1	1	1	2	2	2
Motor Size	kW	0.27	0.27	0.6	0.88	0.6	0.88	0.6	0.88	0.6
Full Load Amps	A	1.2	1.2	2.6	1.7	2.6	1.7	2.6	1.7	2.6
Locked Rotor Amps	A	4.1	4.1	9.2	6.1	9.2	6.1	9.2	6.1	9.2
OPTIONAL EXTRAS										
Short Case Axial Fan - Per Fan										
Quantity		1	1	1	1	1	1	2	2	2
Motor Size	kW	0.61	0.61	1.4	1.94	1.4	1.94	1.4	1.94	1.4
Full Load Amps	A	2.8	2.8	6	3.4	6	3.4	6	3.4	6
Locked Rotor Amps	A	7	7	18	11.9	18	11.9	18	11.9	18
EC Condenser Fan - Per Fan										
Quantity		1	1	1	1	1	1	2	2	2
Motor Size	kW	0.69	0.69	0.73	1.68	0.73	1.68	0.73	1.68	0.73
Full Load Amps	A	3.1	3.1	3.3	2.6	3.3	2.6	3.3	2.6	3.3

Condenser		CR75	CR80	CR95	CR105	CR130	CR140	CR165
Unit Data (1)								
Nominal Run Amps	A	3.3	7.86	4.95	7.86	4.95	10.48	6.6
Maximum Start Amps	A	12.2	27.5	18.3	27.5	18.3	36.7	24.4
Recommended Mains Fuse	A	6	16	10	16	10	16	10
Max Mains Cable Incoming	mm ²	6	6	6	6	6	6	6
Mains Supply 50Hz		400V/3Ph	230V/1Ph	400V/3Ph	230V/1Ph	400V/3Ph	230V/1Ph	400V/3Ph
Fan - Per Fan								
Quantity		2	3	3	3	3	4	4
Motor Size	kW	0.88	0.6	0.88	0.6	0.88	0.6	0.88
Full Load Amps	A	1.65	2.62	1.65	2.62	1.65	2.62	1.65
Locked Rotor Amps	A	6.1	9.17	6.1	9.17	6.1	9.17	6.1
OPTIONAL EXTRAS								
Short Case Axial Fan - Per Fan								
Quantity		2	3	3	3	3	4	4
Motor Size	kW	1.94	1.4	1.94	1.4	1.94	1.4	1.94
Full Load Amps	A	3.4	6	3.4	6	3.4	6	3.4
Locked Rotor Amps	A	11.9	18	11.9	18	11.9	18	11.9
EC Condenser Fan - Per Fan								
Quantity		2	3	3	3	3	4	4
Motor Size	kW	1.68	0.73	1.68	0.73	1.68	0.73	1.68
Full Load Amps	A	2.6	3.3	2.6	3.3	2.6	3.3	2.6

(1) Nominal data based on 35°C ambient and a 50°C mean condensing temperature and using standard fan.

Interconnecting Wiring

(CR26,35,60,75,95,130,165)	L1	○	←
	L2	○	←
	L3	○	←
	N	○	←
	PE	○	←

Mains Incoming 400V / 3Ph + N / 50Hz

Interconnecting wiring

(CR12,16,22,30,50,60,65,80,105,140)	L1	○	←
	N	○	←
	PE	○	←

Mains Incoming 230V / 1Ph + N / 50Hz

NOTES

NOTES



Head Office:

Airedale International Air Conditioning Ltd
Leeds Road
Rawdon
Leeds LS19 6JY
United Kingdom

Tel: +44 (0) 113 239 1000
Fax: +44 (0) 113 250 7219

e-mail: enquiries@airedale.com
website: www.airedale.com



SYSTEMY HVAC Sp. z o.o.
ul.Rydygiera 8, 01-793 Warszawa
tel.: +48 22 101 74 00
fax: +48 22 101 74 01
e-mail: biuro@systemy-hvac.pl
www.systemy-hvac.pl

PART NO:	ISSUE
(TM E)	10/2012
1.1.0	02_2013